

## GENERAL

### Perform a Product Inventory

1. Upon unpacking this product, **PERFORM** an inventory to ensure that all of the required components and hardware have been included; this should include the items detailed in Figure 1, "Magnalock Inventory."

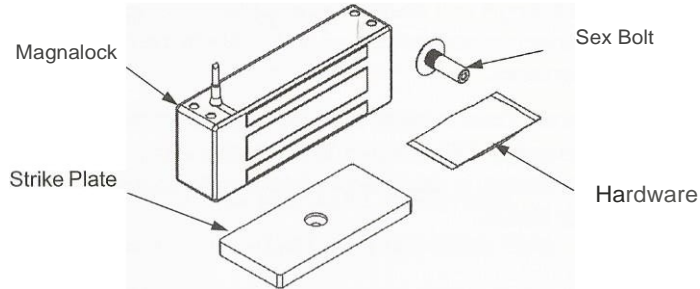

Figure 1. Magnalock Inventory

### Have the Recommended Tools

1. **ENSURE** the following recommended tools are available for installation of the applicable Magnalock:

Power Drill	Hammer 1/8",	Wire Strippers/Cutter
3/8", 1/2" Drill Bits	Center Punch	Crimp Wire Connectors
Masking Tape	Crimp Tool	3/16" Hex Key (Allen Wrench)
Fish Tape or Lead Wire	Multimeter	1/2" Open end or Crescent Wrench

### Perform a Pre-Installation Survey

**NOTE 1:** Additional brackets may be needed for proper installation. Specialized brackets are available through Securitron and its many product distributors.

**NOTE 2:** Figure 2, "Magnalock Installation on an Out-Swinging Door," and Figure 3, "Magnalock Installation on an In-Swinging Door," illustrate the typical mounting methods.

1. **PERFORM** an initial onsite survey to determine a method of mounting and to review the installation plan, taking the following into consideration:
  - Physical strength of mounting areas should be strong enough to meet or exceed the holding force of the required Magnalock.
  - Placement of the Magnalock wiring and protection from potential damage due to intruders or vandals external attack.
  - Accessibility for prevention of potential safety hazards.

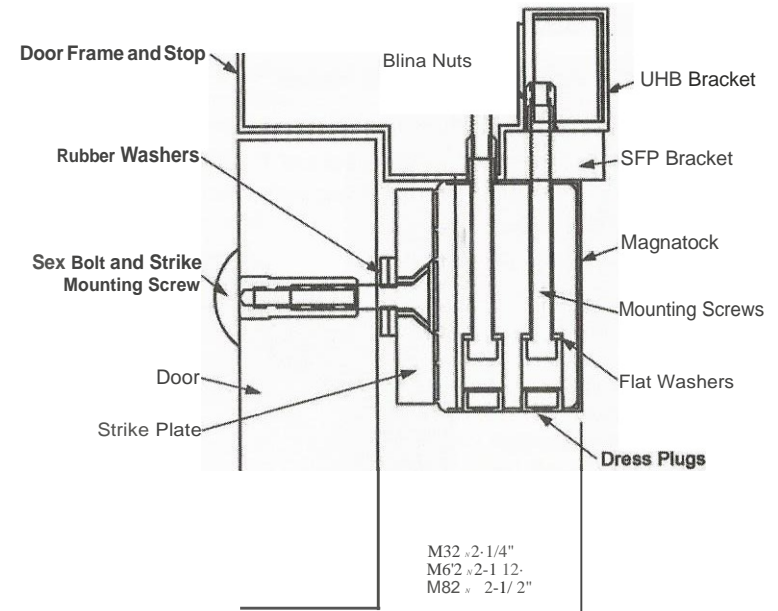

Figure 2. Magnalock Installation on an Out-Swinging Door

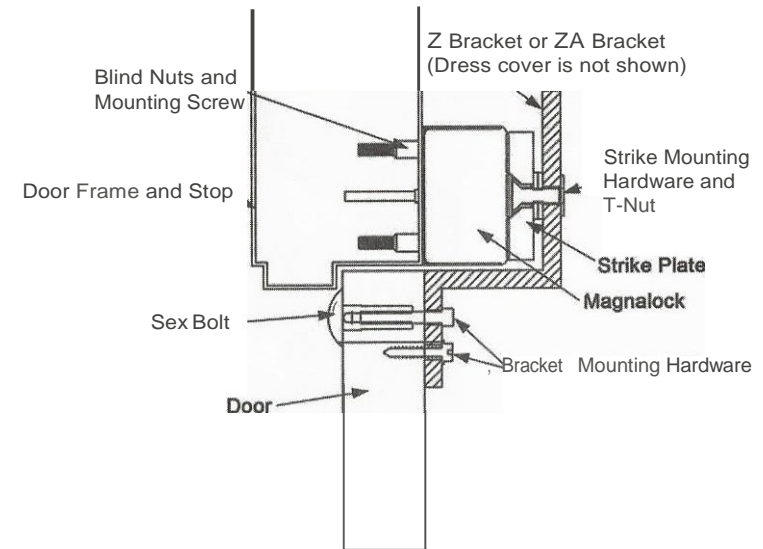

Figure 3. Magnalock Installation on an In-Swinging Door

## INSTALLING A MAGNALOCK

### Attach the Template and Mark the Drill Holes

1. SELECT a mounting location for the Magnalock and strike assembly.

**NOTE:** The edge of the template should be about 1" (25.4 mm) from the latch side of the door to allow proper access at the mounting locations for drilling and tool access.

2. ATTACH the template to the door and frame as shown in Figure 4, "Attaching the Template."

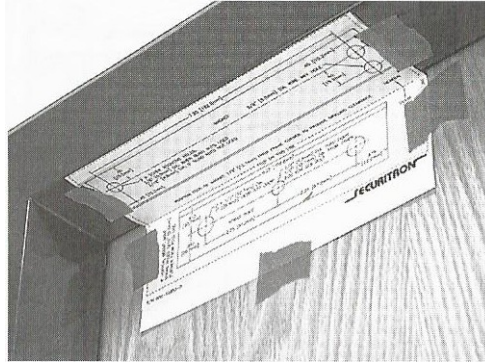

Figure 4. Attaching the Template

- a. IF Installing a strike plate horizontally, **THEN ENSURE** the top edge of the strike will be approximately 1/8" [3.2 mm] below the door frame stop.

- b. IF the strike and magnet are to be mounted vertically, **THEN INCREASE** the clearance between the strike and frame to 3/16" [4.8 mm].

3. **WHEN** the template is attached, **THEN MARK** the location of all holes to be drilled using a center punch (see Figure 5, "Marking Drill Hole Locations").

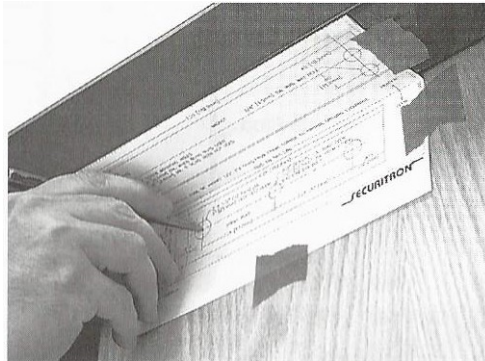

Figure 5. Marking Drill Hole Locations

### Drill the Holes for the Lock Body and Strike Plate

**NOTE 1:** Figure 6, "Installation Drill Holes," provides illustration for the following steps.

**NOTE 2:** Holes #1 and #3 are 1/2" diameter and 1" deep into door. Hole #2 is 1/2" diameter and all the way through the door.

1. DRILL the three holes for the installation of the strike plate.

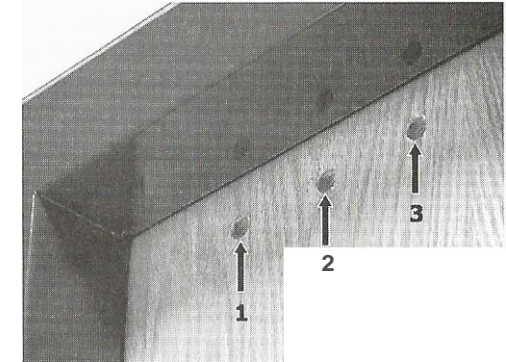

Figure 6. Installation Drill Holes

**NOTE 1:** Figure 7, "Lock Body Drill Holes," provides illustration for the following steps.

**NOTE 2:** Holes A-C are 3/8" diameter.

**NOTE 3:** It is recommended to start drilling with a smaller bit and then use a 3/8" bit to not over size the holes.

2. DRILL the three holes for the installation of the lock body.

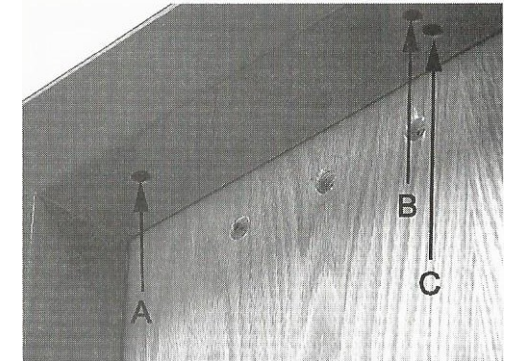

Figure 7. Lock Body Drill Holes

## Install the Blind Nuts

**NOTE:** Figure 8, "Blind Nut Components," Figure 9, "Installing the Blind Nuts," and Figure 10, "Blind Nut Before and After Collapse," provide illustration for the steps in this section.

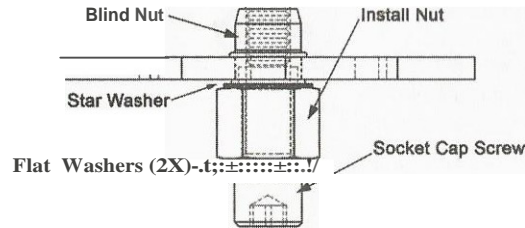

Figure 8. Blind Nut Components

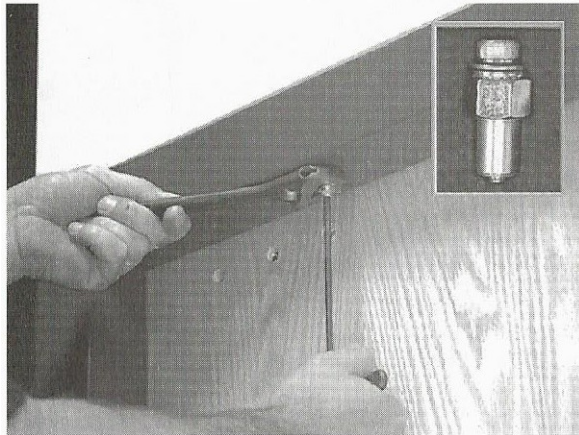

Figure 9. Installing the Blind Nuts

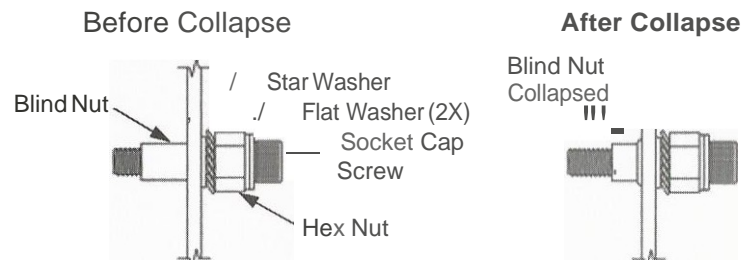

Figure 10. Blind Nut Before and After Collapse

1. INSTALL the blind nuts using the provided collapsing tool.
  - a. INSERT the assembled blind nut and installation tool into a mounting hole to install a blind nut into the 3/8" [9.5 mm] hole (see Figure 8).
  - b. HOLD the install nut using a 1/2" [13 mm] box-end wrench and, at the same time, COLLAPSE the blind nut using a 3/16" [5.0 mm] hex wrench to turn the socket cap screw (see Figure 9).

**NOTE:** The collapsing tool is reusable for several blind nut installations.

- c. REMOVE the collapsing tool when finished.

**NOTE:** Once installed, the blind nuts leave a threaded insert that will accept the case-hardened machine screws provided in the hardware pack.

- d. VERIFY that the blind nut is properly collapsed (see Figure 10).

## Install the Strike Plate

1. ENSURE the following parts are available for strike plate installation (see Figure 11, "Strike Plate Components"):

5/16-18 screw  
 Funnel Bushing  
 Roll Pins (2X)  
 Roll Pin Bushings (2X)  
 Rubber Washers  
 Sex Bolt

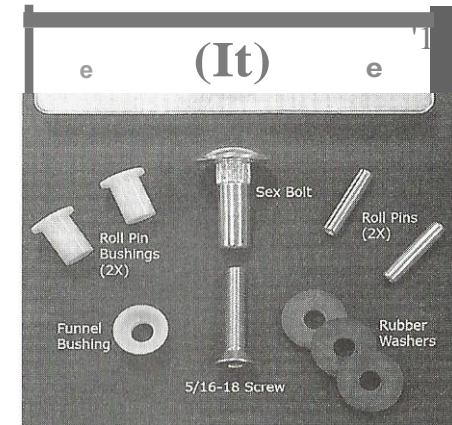

Figure 11. Strike Plate Components

2. Using a hammer, TAP the roll pins into the strike plate until seated (see Figure 12, "Seating the Roll Pins").

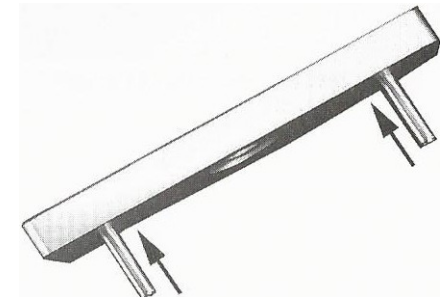

Figure 12. Seating the Roll Pins

3. INSTALL the roll pin bushings into the door (see Figure 13, "Installing the Roll Pin Bushings").

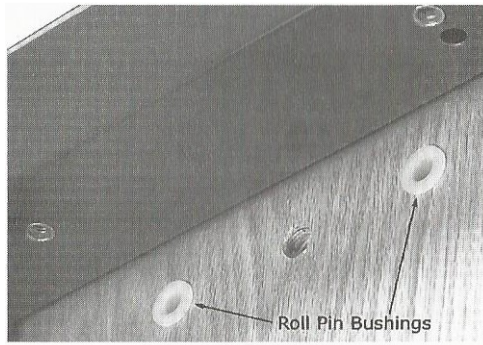

Figure 13. Installing the Roll Pin Bushings

**NOTE:** Figure 14, "Strike Plate Assembly," provides illustration for the Steps 4- 6.

4. INSERT the 5/16-18 bolt through the funnel bushing and strike plate

**NOTE:** It may be necessary to use either 2 or 3 rubber washers depending on final adjustments.

5. INSTALL 2 rubber washers on the 5/16-18 bolt.
6. APPLY thread lock to the 5/16-18 bolt threads.

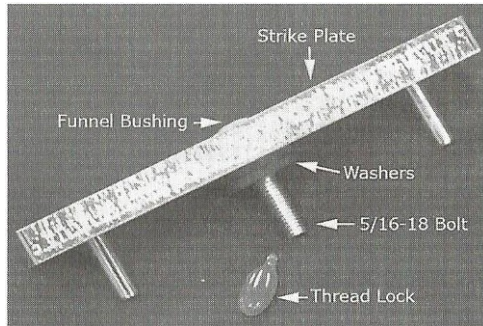

Figure 14. Strike Plate Assembly

**NOTE:** The strike plate is secured to the door via the supplied sex bolt.

7. From the outside of the door, gently TAP the sex bolt into place (see Figure 15, "Installing the Sex Bolt").

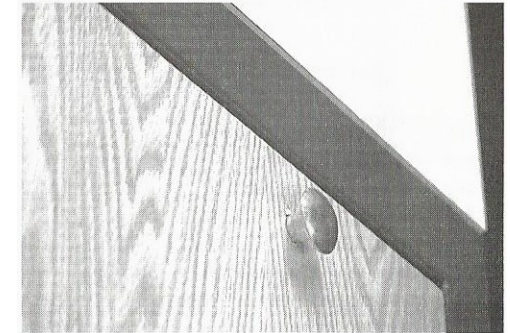
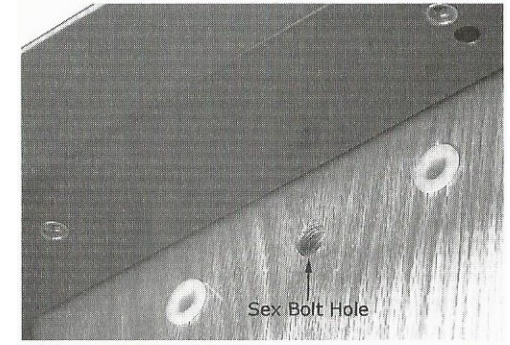

Figure 15. Installing the Sex Bolt

**NOTE:** The center screw should not be over tightened; strike should float.

8. INSTALL the strike by aligning it with the sex bolt and roll pin bushing and then tightening the center screw (see Figure 16, "Installing the Strike Plate").

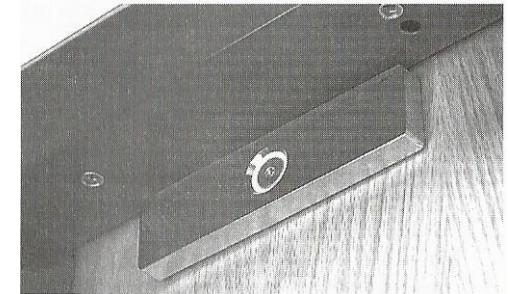

Figure 16. Installing the Strike Plate

## Install the Magnalock

1. PULL the lock wire into frame and to desired location.
2. APPLY thread lock to mounting screws.
3. MOUNT lock body to frame using supplied hardware (see Figure 17, "Installing the Magnalock").

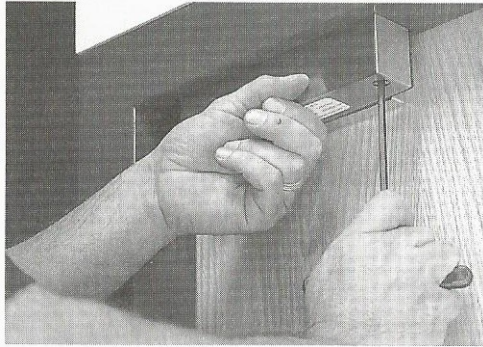

Figure 17. Installing the Magnalock

4. INSERT the tamper finish caps into the mounting screw holes (see Figure 18, "Installing the Tamper Finishing Caps").

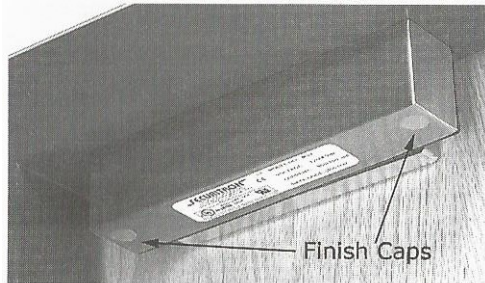

Figure 18. Installing the Tamper Finishing Caps

**CAUTION:** The Magnalock and strike plate must be in proper alignment or the BondSTAT and DPS functions will not operate correctly.

**NOTE 1:** When installing the Magnalock and strike plate, each should be in proper alignment to the other (see Figure 19, "Magnalock and Strike Plate Alignment"). This is considered critical for the operation of both the BondSTAT and OPS. However, there are alignment tolerances for each model of Magnalock, but these should be viewed as the extreme—the installation desire is always total alignment.

**NOTE 2:** The following are the alignment tolerances for the M32, M62, and M82:

Model	X-Coordinate Alignment (+/-)	Y-Coordinate Alignment (+/-)
M32 BID	9/32"	1/8"
M62 B/D	5/16"	1/8"
M82 BID	9/16"	1/8"

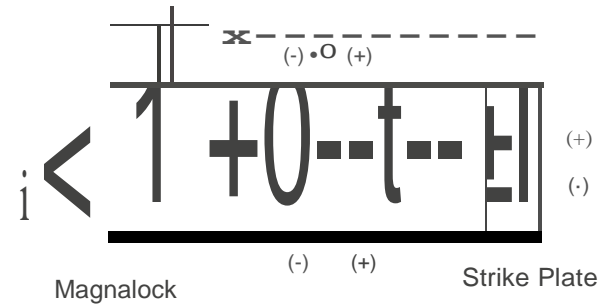

Figure 19. Magnalock and Strike Plate Alignment

5. ENSURE the Magnalock and strike plate are in proper alignment.

**WARNING:** A shock hazard may occur if the Magnalock is operated from a DC power supply that is connected to earth ground or not isolated.

**CAUTION:** The Magnalock must be operated from DC power supply of appropriate capacity and voltage. The DC output of the power supply must not be connected to earth ground but must be isolated, or possible damage to the product could result.

**NOTE:** In order to confirm that the DC outputs of a power supply are isolated, it can be checked with an ohmmeter between earth ground and +V, and then between earth and 0V (negative). There should not be continuity.

6. CONNECT the wiring per Figure 20, "Typical Magnalock Wiring," Figure 21, "Connections for BondSTAT 'B' Version," Figure 22, "Connections for OPS 'D' Version," and Figure 23, "Connections for 'BO' Version."

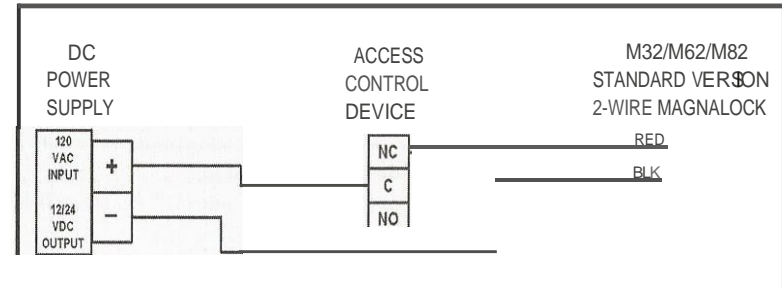

Figure 20. Typical Magnalock Wiring

**NOTE 1:** In Figure 21, the green and white wires supply electrical connection when the lock is ON and secure.

**NOTE 2:** In Figure 21, the orange and white wires supply electrical connection when the lock is OFF or unsecure.

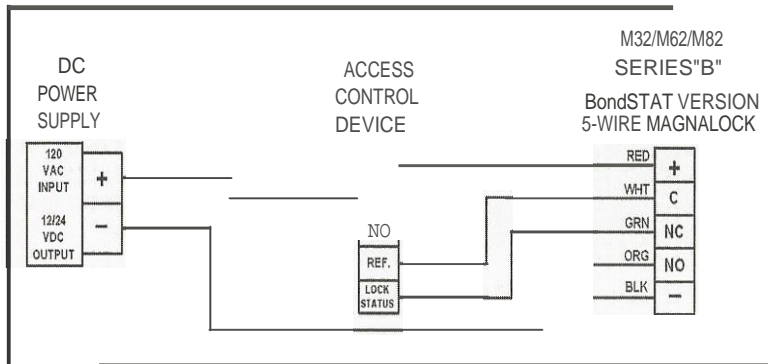

Figure 21. Connections for BondSTAT "B" Version

**NOTE 1:** In Figure 22, the blue and yellow wires supply electrical connection when the door condition is closed.

**NOTE 2:** In Figure 22, the brown and yellow wires supply electrical connection when the door condition is open.

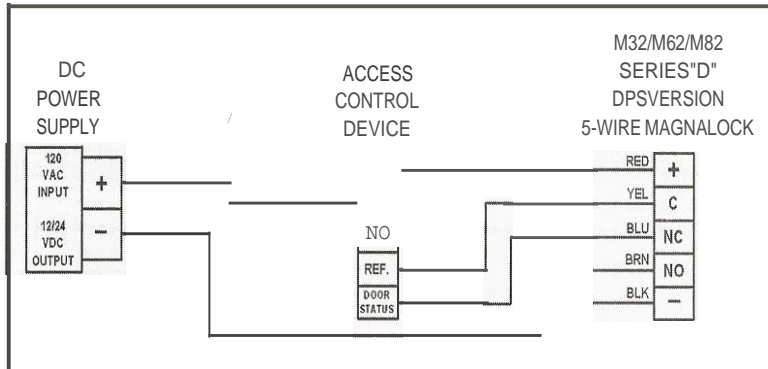

Figure 22. Connections for DPS "D" Version

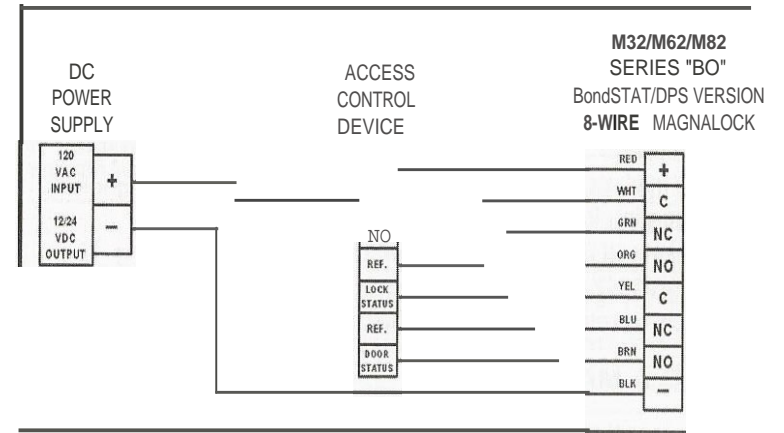

Figure 23. Connections for "BD" Version

### Wire Double Door Status

**NOTE:** When two Magnalocks are used for double door installation, the BondSTAT contacts should be wired in series for proper reporting.

1. CONNECT the green wire of one lock to the white wire of the other as shown in Figure 24, "Double Door Status Wiring."

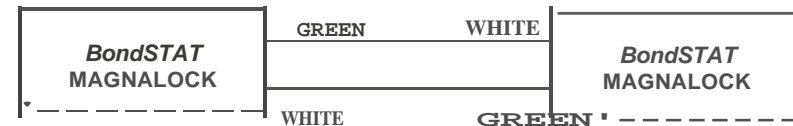

Figure 24. Double Door Status Wiring

### Wire Double Door Status-OPS

**NOTE:** When two Magnalocks are used for double door installation, the OPS contacts should be wired in series for proper reporting.

1. CONNECT the blue wire of one lock to the yellow wire of the other as shown in Figure 25, "Double Door Status Wiring- OPS."

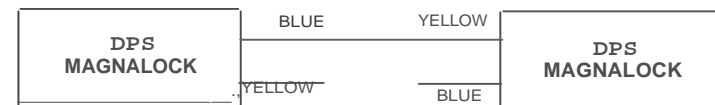

Figure 25. Double Door Status Wiring-OPS

## Wire for Emergency Release

- NOTE 1:** Magnalocks are often wired into a system for quick release in case of emergency.
- NOTE 2:** Manual switching or automatic triggering from a fire alarm system is practical.
- NOTE 3:** It is the user's responsibility to correctly hookup the Magnalock according to the instructions.
- NOTE 4:** Securitron power supplies have terminals for connecting emergency release switches.
- USE a switch or relay to perform break of power.

## MAINTAINING A MAGNALOCK

### Perform an Inspection

- CHECK the rubber washers for elasticity and proper pivoting; TIGHTEN as required.
- CHECK for the build-up of debris on the Magnalock and strike armature; CLEAN as required.
- CHECK for rust on the Magnalock and strike plate armature; CLEAN as required.

### Clean the Magnalock

- CLEAN the Magnalock at the following intervals:
    - Once a year for normal maintenance
    - Every 6 months when minor rusting occurs
    - Every 3 months if rust conditions are severe
  - APPLY rubbing alcohol onto a clean cloth and thoroughly WIPE DOWN the Magnalock and strike plate armature (indoor applications).
- NOTE:** An example of a silicon-based cleaner/lubricant is the following:  
 Super Lube® Aerosol with SYNCOLON®(PTFE)  
 Part Number: 31040-6oz./31110-11 oz./32015-1402.  
 Phone: (631) 567-5300 / Website: www.super-lube.com
- APPLY a silicone-based cleaner/lubricant onto a clean cloth and thoroughly WIPE DOWN the Magnalock and strike plate armature (outdoor applications).
  - USE a plastic dishwashing scrub pad to aid in the removal of rust.

## TROUBLESHOOTING A MAGNALOCK

CHALLENGE	SOLUTION
<b>Lock does not generate a magnetic field</b>	CHECK for specified voltage at Magnalock.
	CHECK for specified current draw at Magnalock.
<b>Reduced holding force</b>	CHECK DC power source is Full-Wave Rectified (Half-wave Rectifier or AC Power unacceptable).
	CHECK for specified voltage at Magnalock.
	CHECK for specified current draw at Magnalock.
	CHECK strike mounting for proper installation.
	CHECK the Magnalock and strike for obstructions and that contact surfaces are properly cleaned.
<b>BondSTAT does not report secure</b>	CHECK for specified voltage at Magnalock.
	Check for specified current draw at Magnalock.
	CHECK strike mounting for proper alignment and pivoting for proper closure to Magnalock.
	CHECK the Magnalock and strike for obstructions and that contact surfaces are properly cleaned.
<b>DPS does not report door status</b>	CHECK strike mounting for proper alignment.
	CHECK for proper door closure.
	CHECK for proper voltage/current on switch.
	CHECK resettable protection device.
<b>Magnalock does not release</b>	ENSURE no voltage is present at Magnalock.
	ENSURE the Magnalock is not drawing current.
	CHECK if the strike is sticky and hard to release.
	CHECK the Magnalock and strike for obstructions and that contact surfaces are properly cleaned.
<b>Magnalock is dirty or rusty</b>	ENSURE the Magnalock is properly cleaned.