



Euro profile cylinder not supplied

EB-260 electric deadbolt incorporates mechanic cylinder to operate manual lock/unlock if power is failure for safety .

Specifications:

- Fail-Security Version (Power to Open)
- Power Input: 12~28 V DC
- Voltage Tolerance: $\pm 10\%$
- Current Draw:
Pull in: 1.0A, Holding: 0.3A@12V DC (at temperature 20°C)
- Operating Temperature: -10~+45°C
- Humidity: 0~95% non-condensing.
- Lock's surface Temperature (when the power is on):
 \leq current temperature +20°C
- Tested to 500000 cycles.
- Face Plate Material: stainless steel
- Autolock Time Delay : 3, 8 ,15 ,25 seconds
- Weight (Approx.) : 1.3 Kg

Solid bolt for superior strength

Greater security is provided by the 16mm diameter (16mm bolt throw) solid stainless steel bolt with hardened magnet core, which has resistant to metal cutting saws. The bolt also rotates freely, making attempts to tamper or cut extremely difficult.

Auto Relocking Timer Setting

Use jumpers to adjust the time between 3 to 25 seconds for door locking time delay. This is the time, which takes the Deadbolt to automatically lock after the door is closed.



3 seconds 8seconds 15 seconds 25 seconds

Adjustable sensor magnet

The maximum sensing distance for the sensor magnet is 5mm. Installed an adjustable sensor magnet in the Strike Plate can improve the sensing problem between the Strike Plate and the reed, which located inside the Deadbolt Lock, caused by the wide door gap.

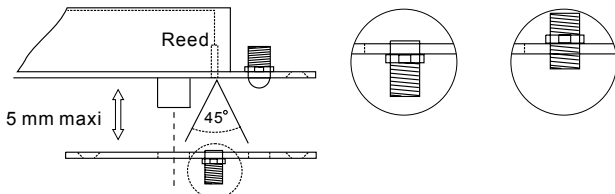

12 to 28V DC self-regulating

The Electric Deadbolt Lock offers 12/24 VDC dual input voltage with self-regulation feature.

Long life solenoids

Special designed solenoid for strength and long life operating lifetime with guaranteed 500,000 operations.

Clamp circuitry

After the bolt projected, the current will drop from 1.0A (the 'pull in' mode) to 0.3A (the holding mode). This design does not only protect the power supply but also extend the lifetime of the Electric Deadbolt Lock.

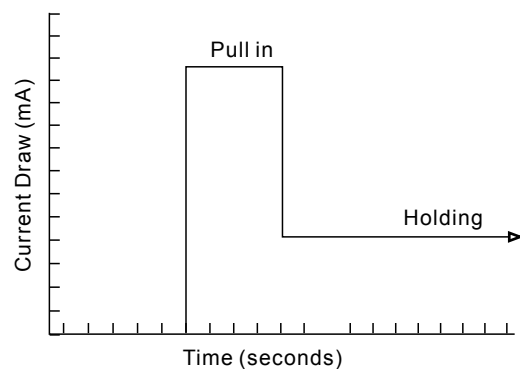



Door Leaf flush installation

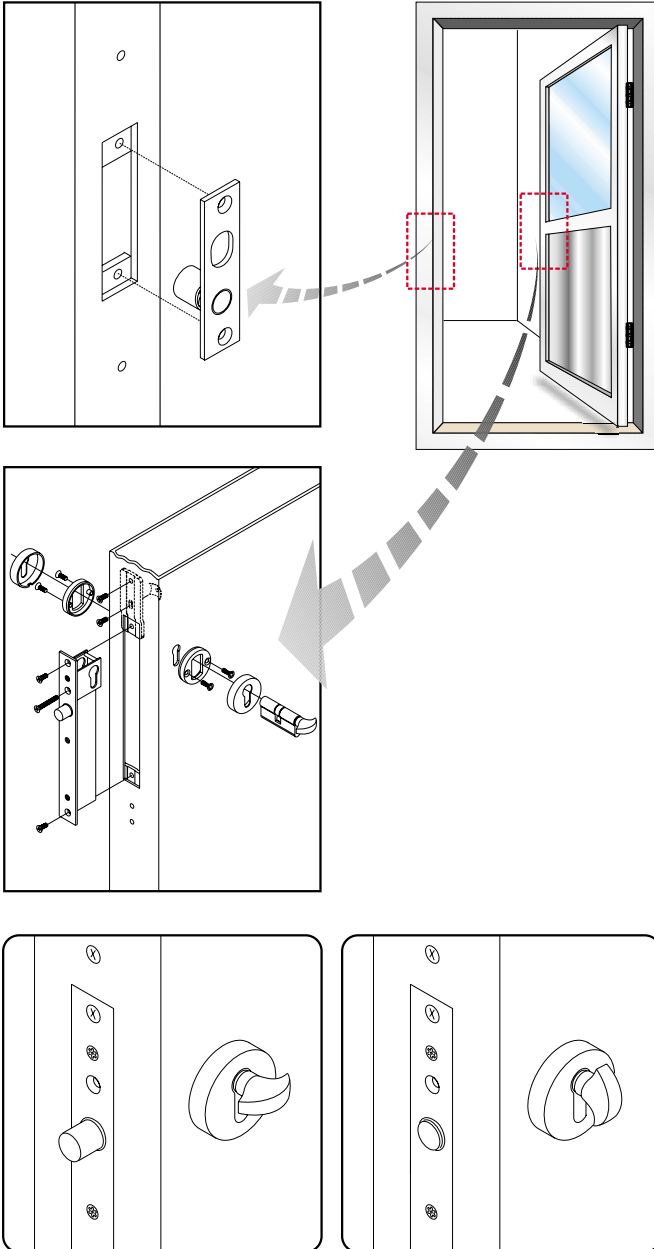

Turn cylinder thumb turn from inside protected premises or use key from outside protected premises.

Option Accessory:

The Door Loop is for protection of extension wiring from damages with high security concerns.

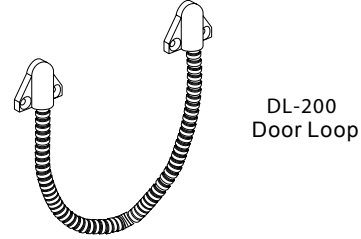

DL-200
Door Loop

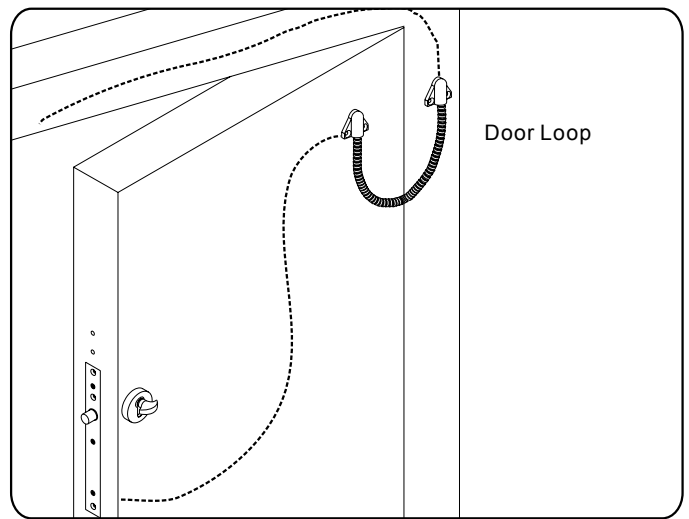

Door Loop

Warranty:

GEM Electric Dropbolts are warranted against defects in material and workmanship while used in normal service for a period of 1 year from the date of sale to the original customer.

Disclaimer:

The information and specifications printed in this manual are current at the time of publication. The GEM policy is one of continual development and improvement; therefore GEM reserves the right to change specifications without notice.

GEM®

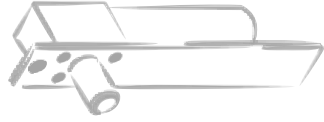

SB-260
ELECTRIC DEADBOLT

Dimension:

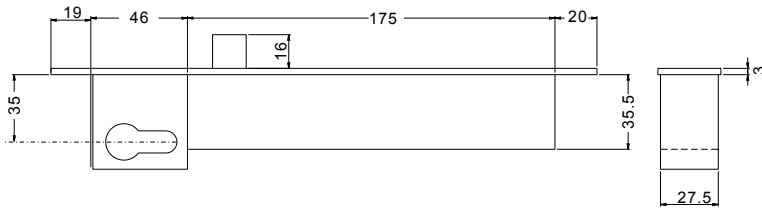
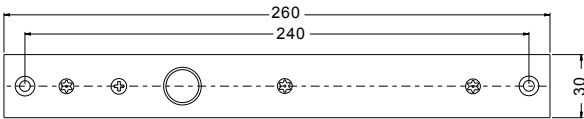
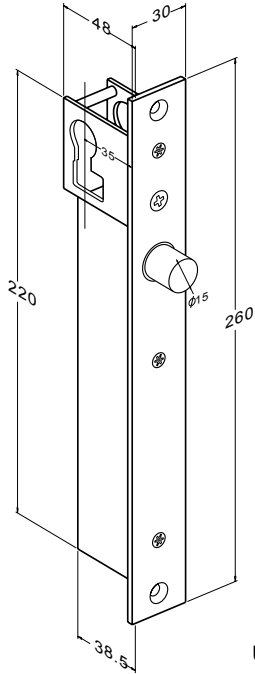

TÜV

E8020847447003

CE

C262804



REGISTERED COMPANY
10076611 CERT. NO. 15118 022

The products are manufactured under an ISO 9001 Certified Quality Management Program environment back its product quality, performance and commitment to customer satisfaction.