



**Fixing Template for: 9943N5&N6, 9944N5&N6,  
9945N5L&R, 9945N6L&R, 9946N5L&R, 9946N6L&R**

(suffix 'F' included to above denotes radiused forend)

FT9943N

Issue 01-09/21 NOTE: 9943N5, P5,N6, P6 & 9944N5, P5, N6 & P6 NOT CERTIFIRE

**FRAME PREP DETAILS**

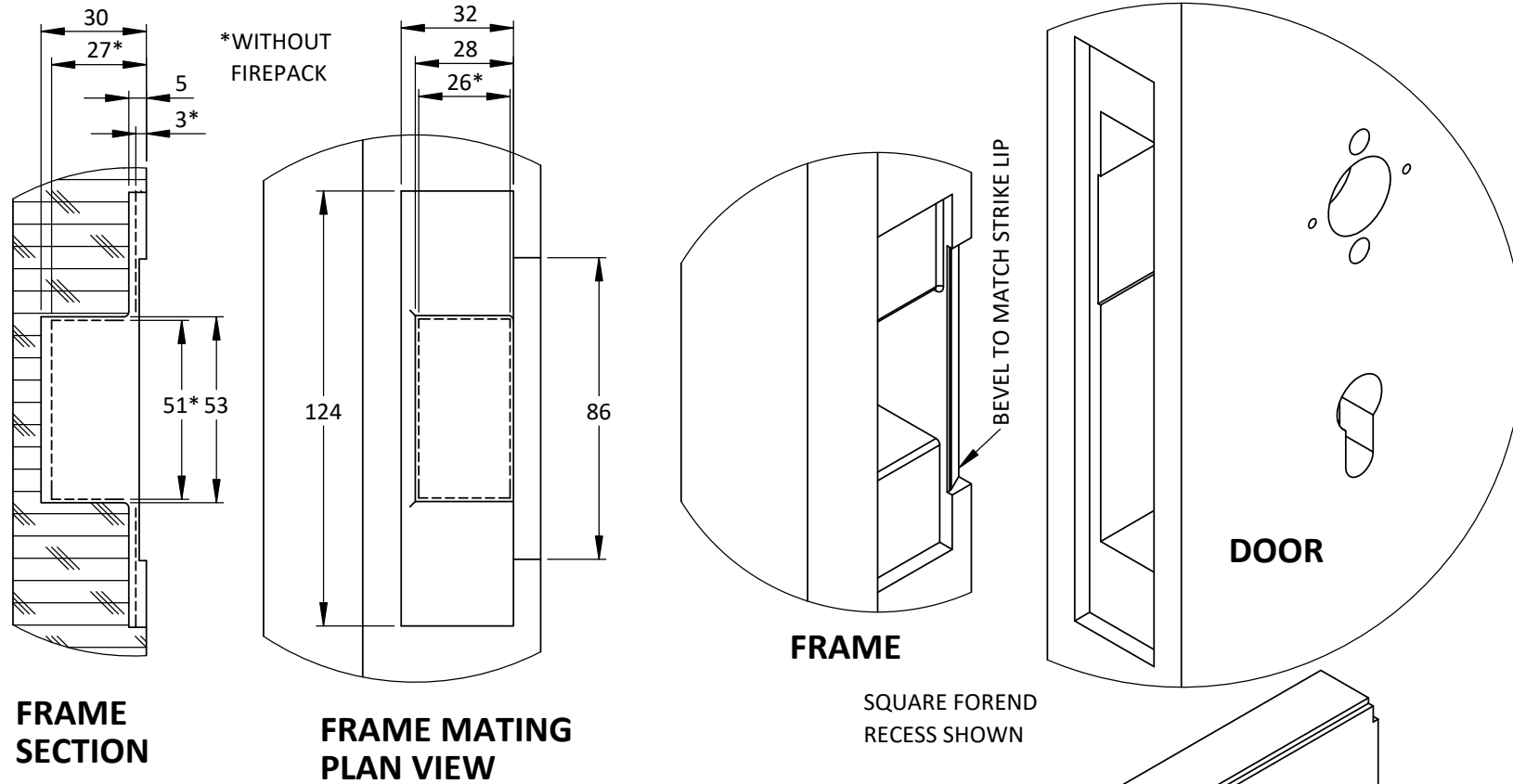

Dimensions shown are guidance only, and for preparation of door, refer to actual lockcase to make allowances for cutting tolerances.

- Q =  $\varnothing 8$  Through holes for Quadaxial Furn.
- \* =  $\varnothing 25$  Bore - use drilling jig provided with Quadaxial lever furniture.
- P = Pilot holes for No. 6 self tapping screws

**DOOR PREP DETAILS**

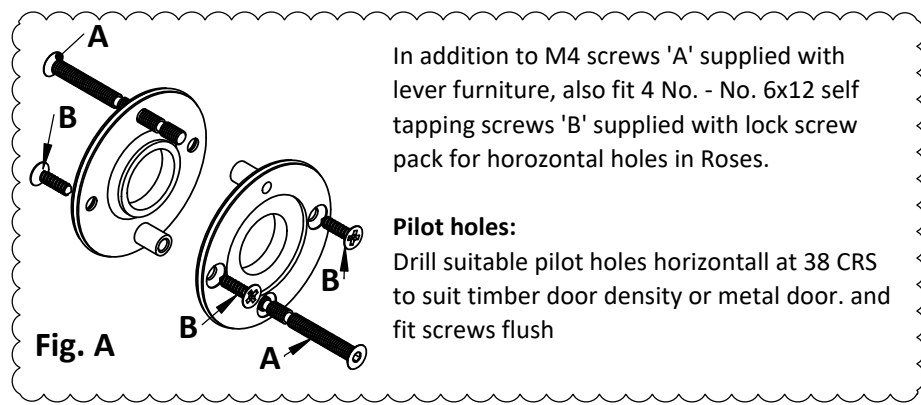
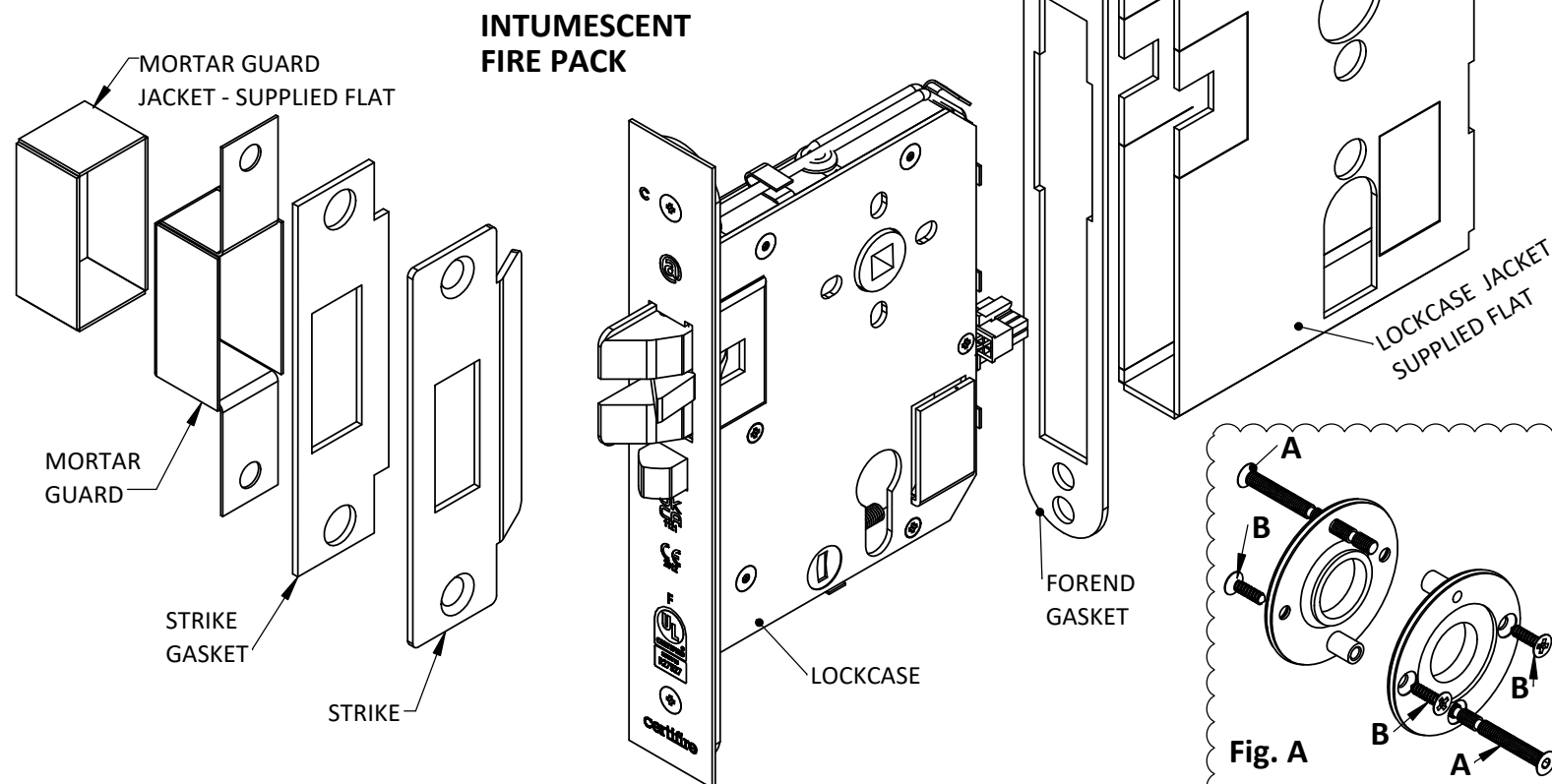
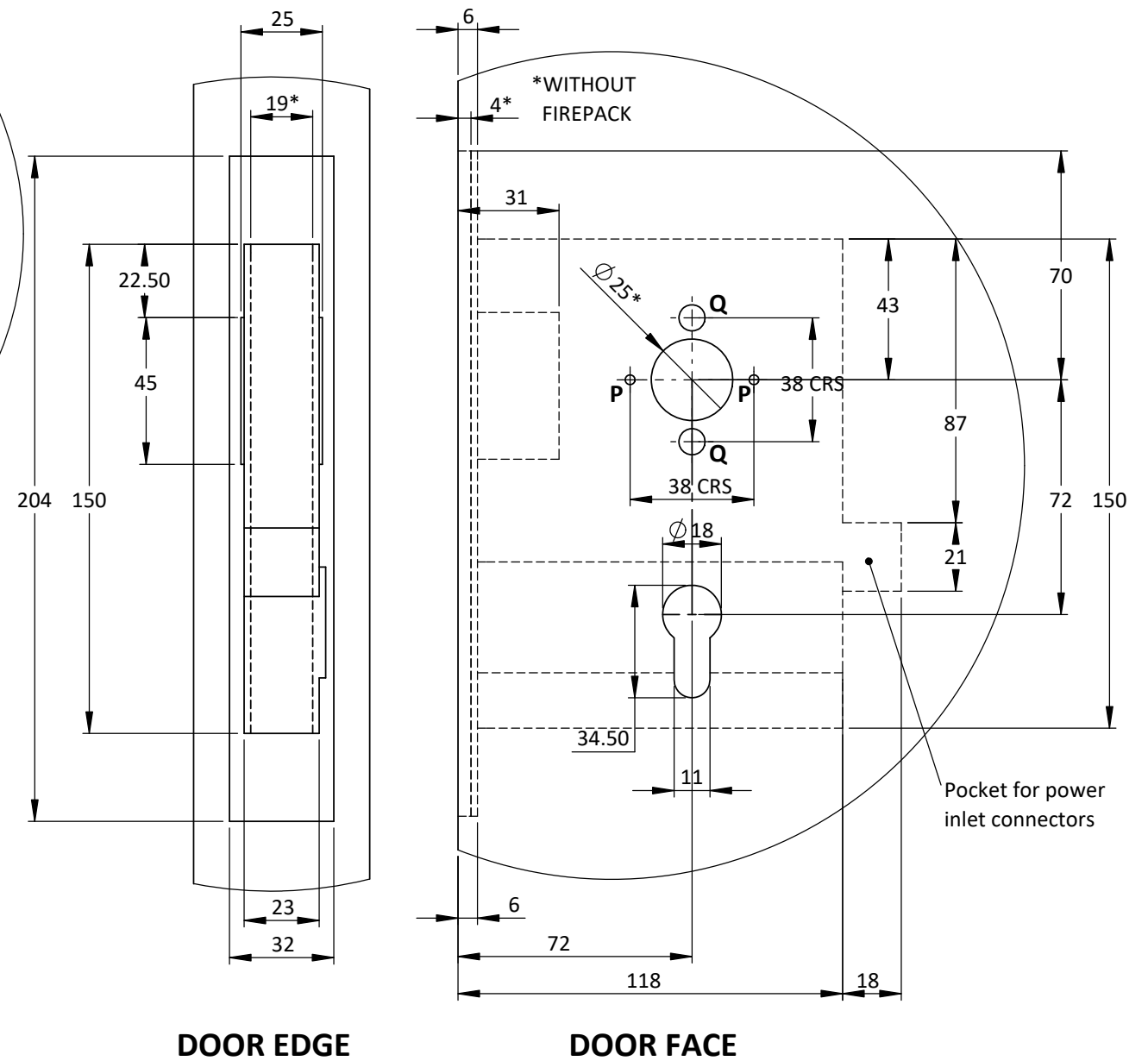

When this product is used for Escape/Exit door, selection of the following EN 179:2008 compliant items must be used:

- Lever Furniture:** 3502D, 3506D, 3510
- Spindle:** Half Spindles - 9052NT
- Through Split Spindles:** 9069T,
- Cylinders:** Euro profile cylinders with DIN compliant Cam.



Recycle responsibly